



BUFFER MODULE

- Buffering with electrolytic capacitors instead of lead acid batteries
- Buffering of 48V loads
- Minimum hold-up time 0.1s at 20A, 0.2s at 10A and longer hold-up time at lower loads
- Clear status indication by status LED and signaling terminals
- Quick-connect spring-clamp terminals
- 3 Years warranty

GENERAL DESCRIPTION

The UF20 buffer module is a supplementary device for regulated DC 48V power supplies, which can be used for various purposes:

- Deliver DC-power to bridge failures of the DC voltage supply system.
- Extend the hold-up time after loss of the AC power.
- Deliver extra short-term peak current above the current rating of the power supply.

It utilizes service-free electrolytic capacitors for storing the energy which allows usage even at ambient temperatures up to +70°C.

The buffer module does not require any control wiring. It can be added in parallel to the load circuit at any given point.

Buffer modules can be connected in parallel to increase the output ampacity or the hold-up time.

SHORT-FORM DATA

Supply voltage	DC 48V ^{-20%/+25%}	38.4-60Vdc
Required voltage to charge capacitors	46Vdc	
Threshold voltage for buffer mode	45V / V _{IN} -2V	Selectable
Buffer voltage	45V / V _{IN} -2V	Selectable
Buffer current	20A	
Charging time	Typ. 21s	
Current consumption	Typ. 40mA Max. 500mA	Stand-by mode During charging
Power dissipation	1.9W	Stand-by mode
Buffer time	Min. 100ms Min. 200ms Typ. 150ms Typ. 300ms Typ. 21s	At 45V, 20A At 45V, 10A At 45V, 20A At 45V, 10A At 45V, 0.1A
Temperature range	-25°C to +70°C	Operational
Dimensions	64x124x102mm	WxHxD
Weight	740g / 1.63lb	

ORDER NUMBERS

Buffer Module	UF20.481	
Accessory	ZM1.WALL	Panel/ wall-mount bracket
	ZM14.SIDE	Side-mount bracket

MARKINGS



INDEX

	Page		Page
1. Intended Use	3	15. Terminals and Wiring	10
2. Installation Notes	3	16. Front Side and User Elements	11
3. Functional Description	4	17. EMC	12
4. Electrical Ratings	5	18. Environment	13
5. Selection of the Back-up Threshold Voltage	6	19. Protection Features	13
6. Buffer Time	6	20. Safety Features	13
7. Charging Time	7	21. Dielectric Strength	14
8. Operating Diagrams	7	22. Approvals	14
9. Active Signal	8	23. Physical Dimensions and Weight	15
10. Ready Signal	8	24. Accessories	16
11. Inhibit Input	8	24.1. ZM1.WALL - Wall mounting bracket	16
12. Efficiency and Power Losses	9	24.2. ZM14.SIDE - Side Mounting Bracket	17
13. Lifetime Expectancy and MTBF	9	25. Wiring Diagrams	18
14. Functional Diagram	10		

The information given in this document is correct to the best of our knowledge and experience at the time of publication. If not expressly agreed otherwise, this information does not represent a warranty in the legal sense of the word. As the state of our knowledge and experience is constantly changing, the information in this data sheet is subject to revision. We therefore kindly ask you to always use the latest issue of this document (available under www.pulspower.com). No part of this document may be reproduced or utilized in any form without our prior permission in writing.

Some parts of this unit are patent by PULS (US patent No 091662,063, Des. 424,529, ...).

TERMINOLOGY AND ABBREVIATIONS

Power supply mode	Describes a condition where the supply voltage is in the rated supply voltage range and the supplying power supply can deliver a sufficient amount of current for the buffer module and the load. The mode can also be called "Normal mode".
Buffer mode	Describes a condition where the input voltage is below the transfer threshold level, the unit is running on capacitors (buffering) and the output is loaded within the allowed limits. The mode can also be called "Capacitor mode".
Inhibit mode	Describes a condition where buffering is disabled on purpose (e.g. for service actions).
T.b.d.	To be defined, value or description will follow later.
DC 48V	A figure displayed with the AC or DC before the value represents a nominal voltage with standard tolerances included. E.g.: DC 12V describes a 12V battery disregarding whether it is full (13.7V) or flat (10V).
48Vdc	A figure with the unit (Vdc) at the end is a momentary figure without any additional tolerances included.
may	A key word indicating flexibility of choice with no implied preference.
shall	A key word indicating a mandatory requirement.
should	A key word indicating flexibility of choice with a strongly preferred implementation.

1. INTENDED USE

This device is designed for installation in an enclosure. Use an appropriate enclosure which protects against mechanical, electrical and fire hazards.

This device is intended for professional use in areas such as in industrial control, office, communication, and instrumentation equipment.

Do not use this device in equipment or systems where malfunction may cause severe personal injury or threaten human life.

2. INSTALLATION NOTES

This device may only be installed and put into operation by qualified personnel.

This device does not contain serviceable parts or fuses.

If damage or malfunction should occur during installation or operation, immediately turn power off and send unit to the factory for inspection.

The unit must be powered from a SELV source (according to IEC 60950-1), PELV source (according to IEC 62477-1) or an Isolated Secondary Circuit (according to UL 508) power source.

Use DIN-rails according to EN 60715 with a height of 7.5 or 15mm.

Mounting orientation must be power terminals on top of the unit.

Do not obstruct air flow as the unit is convection cooled. Ventilation grid must be kept free of any obstructions.

Signal lines (ready, active and inhibit) must be shorter than 30m.

Use an appropriately sized power supply, which can deliver the additional required internal current consumption (including the charging current) specified as input current in the table of chapter 4 and Fig. 4-1.

The following installation clearances must be maintained:

- Left / right: 0mm
- On top of the unit: 40mm
- On bottom of the unit: 20mm

Agency approvals apply only for altitudes up to 2000m.

Maximum surrounding air temperature: +70°C / +158°F.

Caution for Canada: For use in a controlled environment according to CSA 22.2 No 107.1-01.

WARNING

Risk of electrical shock, fire, personal injury or death.

- Turn power off before working on the device. Protect against inadvertent re-powering.
- Make sure that the wiring is correct by following all local and national codes.
- Do not modify or repair the unit.
- Do not open the unit as dangerous voltages may be present inside.
- Use caution to prevent any foreign objects from entering the housing.
- Do not use in wet locations or in areas where moisture or condensation can be expected.
- Do not touch during power-on, and immediately after power-off. Hot surfaces may cause burns.

3. FUNCTIONAL DESCRIPTION

Working principle

When the power supply provides sufficient voltage, the buffer module stores energy in the integrated electrolytic capacitors. In case of a voltage dip or loss, this energy is released to the DC bus in a regulated process.

Bridges mains faults without interruption

Statistic show that 80% of all mains fault lasts less than 0.2s. These mains faults are completely bridged by the buffer unit up to 10A load current. For higher load currents use multiple buffer modules in parallel. This increases the reliability of the system as a whole.

Extended hold-up time

Once mains power fails or is switched off, the buffer unit will continue to provide the load current for a defined period of time. Process data can be saved and processes can be terminated before the DC power switches off. Controlled restarts are subsequently possible.

Easy to handle, expandable and maintenance-free

The buffer module does not require any control wiring. It can be added parallel to the load circuit at any given point. Buffer modules can be connected in parallel to increase the output ampacity or the hold-up time.

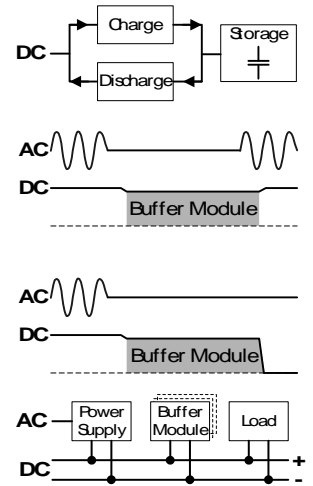

Fig. 3-1 Typical wiring diagram

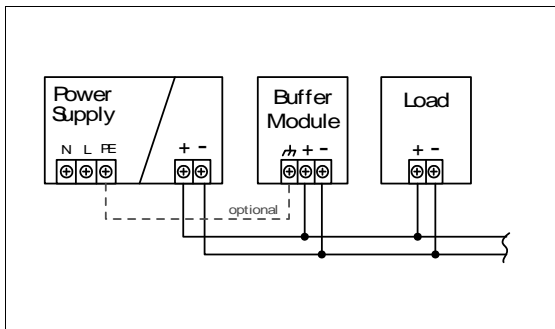
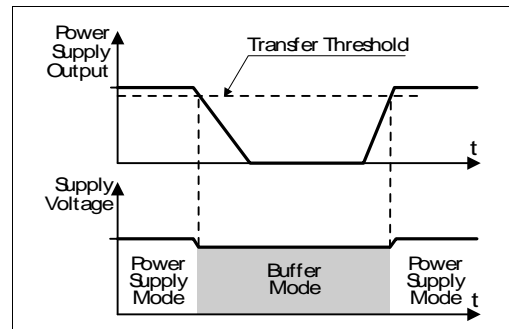

Fig. 3-2 Transfer behavior



4. ELECTRICAL RATINGS

Supply voltage	Nom.	DC 48V ^{-20%/+25%}	
Supply voltage range ¹⁾	Nom.	38.4 - 60Vdc	
Normal operating voltage range ²⁾	Typ.	46 – 60Vdc	
Transfer voltage for switching into buffer mode	Typ.	45Vdc	Back-up threshold jumper set to "45V fixed"
	Typ.	V _{IN} – 2V	Back-up threshold jumper set to "V _{IN} – 2V" See also chapter 5.
Transfer voltage for switching from buffer mode into power supply mode	Typ.	45Vdc	Back-up threshold jumper set to "45V fixed"
	Typ.	V _{BUFFER} + 2V	Back-up threshold jumper set to "V _{IN} – 2V" See also chapter 5.
Buffer voltage	Typ.	Same as the transfer voltage for switching into buffer mode.	
Ripple and noise voltage - in buffer mode	Max.	250mVpp	At 5A generated by the buffer module
	Max.	400mVpp	At 10A generated by the buffer module
	Max.	600mVpp	At 20A generated by the buffer module Defined at 20Hz to 20MHz, 50Ohm
- in power supply mode		The ripple and noise voltage is defined by the power supply.	
Current consumption	Typ.	40mA	When capacitor is fully charged
	Min.	300mA	During charging of the capacitors
	Max.	500mA	During charging of the capacitors
Power dissipation	Typ.	1.9W	When capacitor is fully charged
Buffer current	Min.	20A	
Buffer current overload behavior		Electronically limited, buffering stops and capacitor gets discharged below 34V. See Fig. 4-2.	
Allowed voltage between supply voltage and chassis ground	Max.	60Vdc or 42.4Vac	Continuous, IEC 62477-1
Capacitive and inductive loads		No limitation	

1) Supply Voltage Range:

At voltages within the input voltage range, control functions such as LEDs, monitoring features, relay contacts, etc. are functioning normally. Within the input voltage range the unit can either be in power supply mode or in buffer mode.

2) Normal Operating Voltage Range:

The normal operating voltage range describes the supply voltage, which supports the full functionality of the buffer module (including charging) but without entering the buffer mode.

Fig. 4-1 Selection of an appropriate power supply

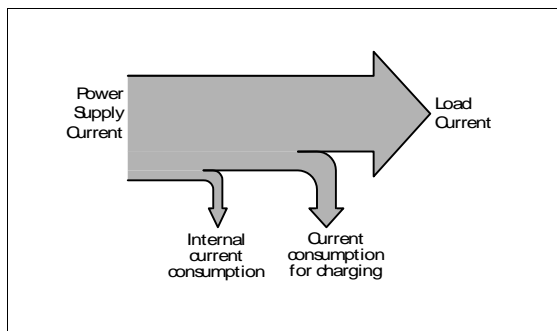
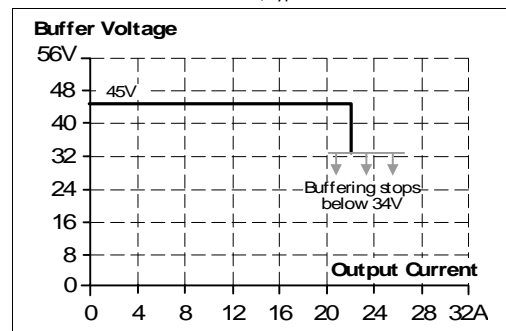

Fig. 4-2 Output characteristic in buffer mode, 45V fixed mode, typ.



5. SELECTION OF THE BACK-UP THRESHOLD VOLTAGE

The buffer behavior can be selected with the back-up jumper selector between “Fixed Mode” and “Variable Mode”.

Fixed Mode: (Jumper in position „2-3“ or „45V fixed“)

If the supply output voltage falls below 45V, buffering starts and the supply voltage will be kept at this level.

This adjustment is recommended:

- when power supplies other than the DIMENSION Q-series are used
- with back-feeding loads
- when the buffer module is placed close to the load or
- whenever in doubt.

Variable Mode: (Jumper in position „1-2“ or „ $V_{IN} - 2V$ “)

Buffering starts if the supply voltage decreases by more than 2V. Buffering ends when supply voltage increases by more than 2V

Voltage changes slower than 1.1V/s will be ignored if the voltage is above 45V. Below 45V buffering starts immediately.

This adjustment is recommended for any application where 45V is too low for the application or when the buffer module is placed close to the power supply.

The factory setting is fixed mode, A missing jumper means also fixed mode.

6. BUFFER TIME

The buffer time (sometimes also called autonomy time) is the maximum period of time for which the capacitor can maintain the required output current. The buffer time mainly depends on the output current in buffer mode.

To increase the buffer time any given number of buffer modules can be connected in parallel.

Buffer time	Min.	100ms	At 45V, 20A
	Min.	200ms	At 45V, 10A
	Typ.	150ms	At 45V, 20A
	Typ.	300ms	At 45V, 10A
	Typ.	21s	At 45V, 0.1A

Fig. 6-1 Buffer time, typ.

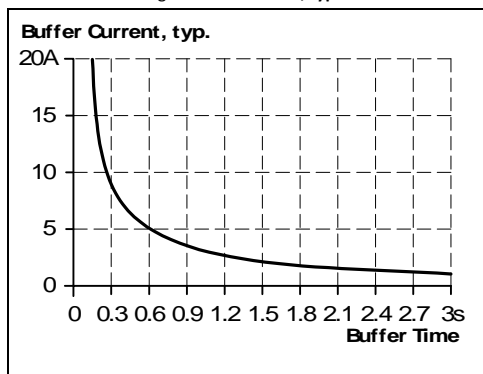
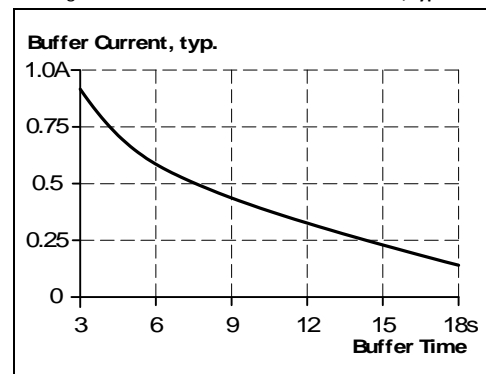

Fig. 6-2 Buffer time for small buffer currents, typ.



7. CHARGING TIME

Charging of the internal capacitors is indicated by the status LED, which is flashing with a slow frequency (1.25Hz).

Charging time	Min.	22s	Initial charging ¹⁾
	Max.	32s	Initial charging ¹⁾
	Min.	17s	Re-charging ²⁾
	Max.	25s	Re-charging ²⁾

- 1) Initial charging is the first charge after voltage is applied to the buffer module.
- 2) Re-charging is the charging of the internal capacitors after voltage interruptions shorter than 2minutes.

Fig. 7-1 Charging time, re-charging

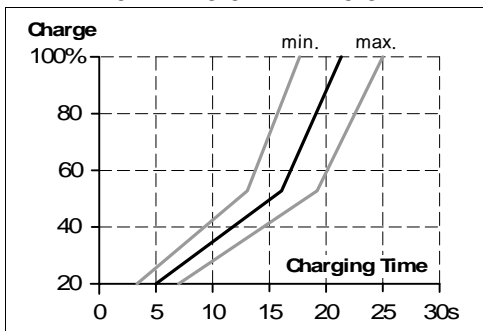

8. OPERATING DIAGRAMS

Fig. 8-1 Operating diagram

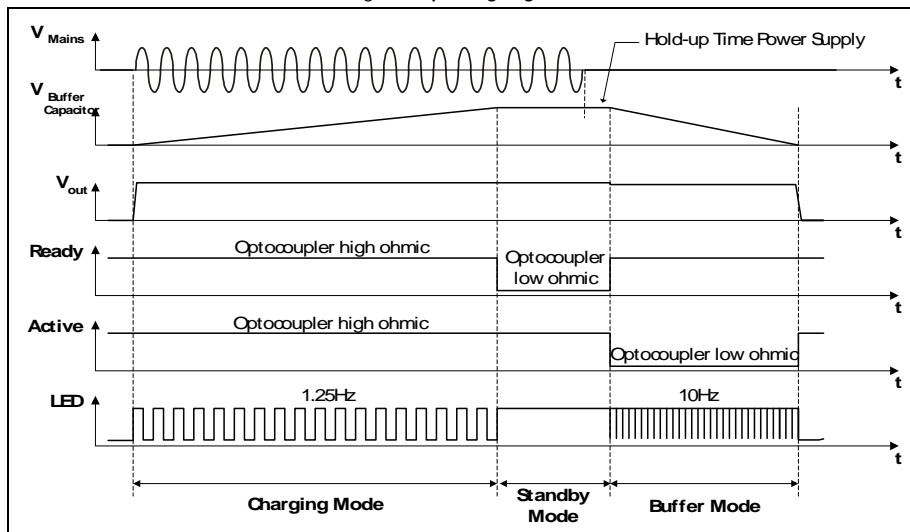
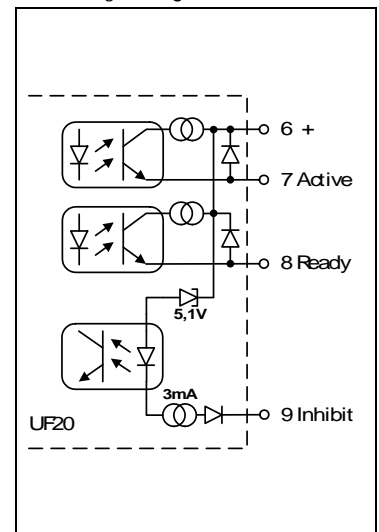

Fig. 8-2 Signal schematic



9. ACTIVE SIGNAL

The signal "Active" (pin 7) is an opto-coupler output which is low ohmic while buffer capacitors are discharged.
Wiring scheme see Fig. 8-2, Fig. 25-1 and Fig. 25-2.

Signal voltage	Max.	60Vdc	Voltage between pin 6 and 7
Signal current	Max.	6mA	
Voltage drop across opto-coupler		1.2V / 3.3V	At 1mA / 5mA while opto-coupler is low ohmic
Leakage current	Max.	50µA	While opto-coupler is high ohmic
Isolation voltage	See chapter 21.		

10. READY SIGNAL

The signal "Ready" (pin 8) is an opto-coupler output which is low ohmic when buffer capacitors are fully charged.
Wiring scheme see Fig. 8-2, Fig. 25-1 and Fig. 25-2.

Signal voltage	Max.	60Vdc	Voltage between pin 6 and 8
Signal current	Max.	6mA	
Voltage drop across opto-coupler		1.2V / 3.3V	At 1mA / 5mA while opto-coupler is low ohmic
Leakage current	Max.	50µA	While opto-coupler is high ohmic
Isolation voltage	See chapter 21.		

11. INHIBIT INPUT

Buffering can be disabled or interrupted with the inhibit input (pin 9). Therefore, pin 6 should be connected to the positive pole of the terminal voltage or to the external control voltage and pin 9 must be connected to the corresponding negative pole.

Inhibiting the unit also discharges the internal capacitors. Charging of the capacitor is not possible when the buffer module is in inhibit mode.

Wiring scheme see Fig. 8-2, Fig. 25-1 and Fig. 25-2.

Signal voltage	Max.	60Vdc (between pin 6 and pin 9)
Signal current	Max.	4mA, current limited
Inhibit mode	The unit does not buffer (or stops buffering) if the voltage between pin 6 and pin 9 is higher than 10V. Below 6V buffering will function again.	
Isolation voltage	See chapter 21.	

12. EFFICIENCY AND POWER LOSSES

Efficiency	Typ.	>99%	Power supply mode, 20A output current, capacitors fully charged
Power losses	Typ.	1.9W	Power supply mode, 0A output current, capacitors fully charged

13. LIFETIME EXPECTANCY AND MTBF

Calculated lifetime expectancy ^{*)}	161 000h ^{*)}	Stand-by mode, 40°C
	457 000h ^{*)}	Stand-by mode, 25°C
MTBF ^{**)} SN 29500, IEC 61709	2 348 000h	Stand-by mode, 40°C
	4 231 000h	Stand-by mode, 25°C
MTBF ^{**)} MIL HDBK 217F	405 000h	Stand-by mode, 40°C, Ground Benign GB40
	636 000h	Stand-by mode, 25°C Ground Benign GB25
	134 000h	Stand-by mode, 40°C, Ground Fixed GF40
	198 000h	Stand-by mode, 25°C Ground Fixed GF25

^{*)} The **calculated lifetime expectancy** shown in the table indicates the minimum operating hours (service life) and is determined by the lifetime expectancy of the built-in electrolytic capacitors. Lifetime expectancy is specified in operational hours and is calculated according to the capacitor's manufacturer specification. The manufacturer of the electrolytic capacitors only guarantees a maximum life of up to 15 years (131 400h). Any number exceeding this value is a calculated theoretical lifetime which can be used to compare devices.

^{**)} **MTBF** stands for **Mean Time Between Failure**, which is calculated according to statistical device failures, and indicates reliability of a device. It is the statistical representation of the likelihood of a unit to fail and does not necessarily represent the life of a product.
The MTBF figure is a statistical representation of the likelihood of a device to fail. A MTBF figure of e.g. 1 000 000h means that statistically one unit will fail every 100 hours if 10 000 units are installed in the field. However, it can not be determined if the failed unit has been running for 50 000h or only for 100h.

14. FUNCTIONAL DIAGRAM

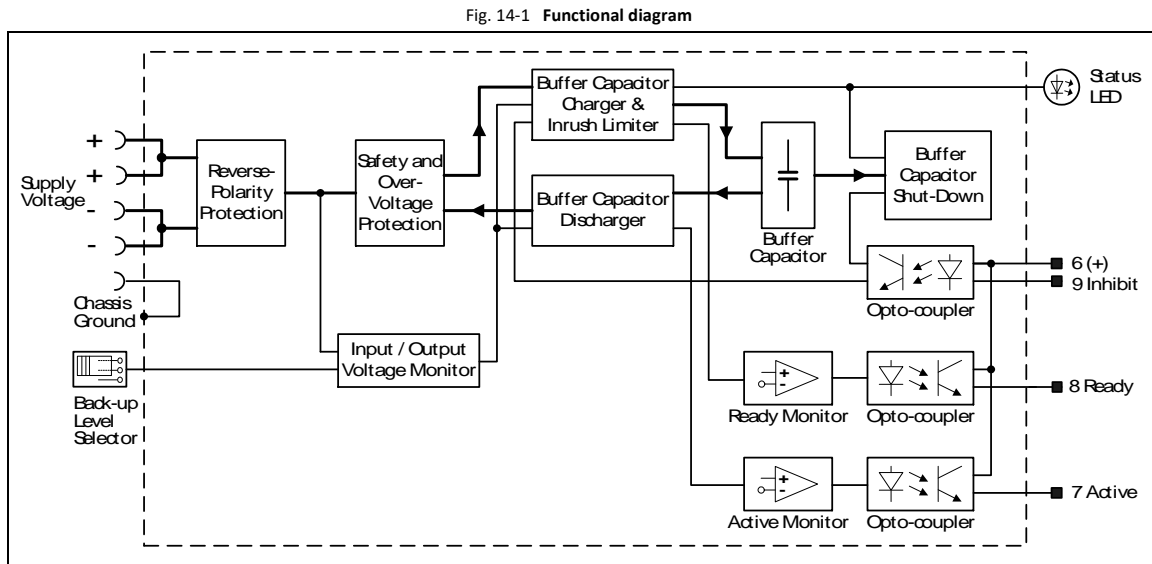

15. TERMINALS AND WIRING

The terminals are IP20 finger safe constructed and suitable for field and factory wiring.

	Supply voltage, chassis ground	Signals
Type	Quick-connect spring-clamp terminals	Pluggable screw terminals
Solid wire	Max. 6mm ²	Max. 2.5mm ²
Stranded wire	Max. 4mm ²	Max. 2.5mm ²
American Wire Gauge	Max. AWG 20-10	AWG 22-14
Max. wire diameter	Max. 2.8mm (including ferrules)	2.25mm (including ferrules)
Wire stripping length	Typ. 10mm / 0.4inch	6mm / 0.25inch
Tightening torque	Not applicable	0.4Nm / 3.5lb.inch
Screwdriver	Not applicable	3mm slotted

Instructions:

- Use appropriate copper cables that are designed for minimum operating temperatures of:
 60°C for ambient up to 45°C and
 75°C for ambient up to 60°C and
 90°C for ambient up to 70°C minimum.
- Follow national installation codes and installation regulations!
- Ensure that all strands of a stranded wire enter the terminal connection!
- Unused terminal compartments should be securely tightened or closed.
- Ferrules are allowed.

16. FRONT SIDE AND USER ELEMENTS

Fig. 16-1 Front side

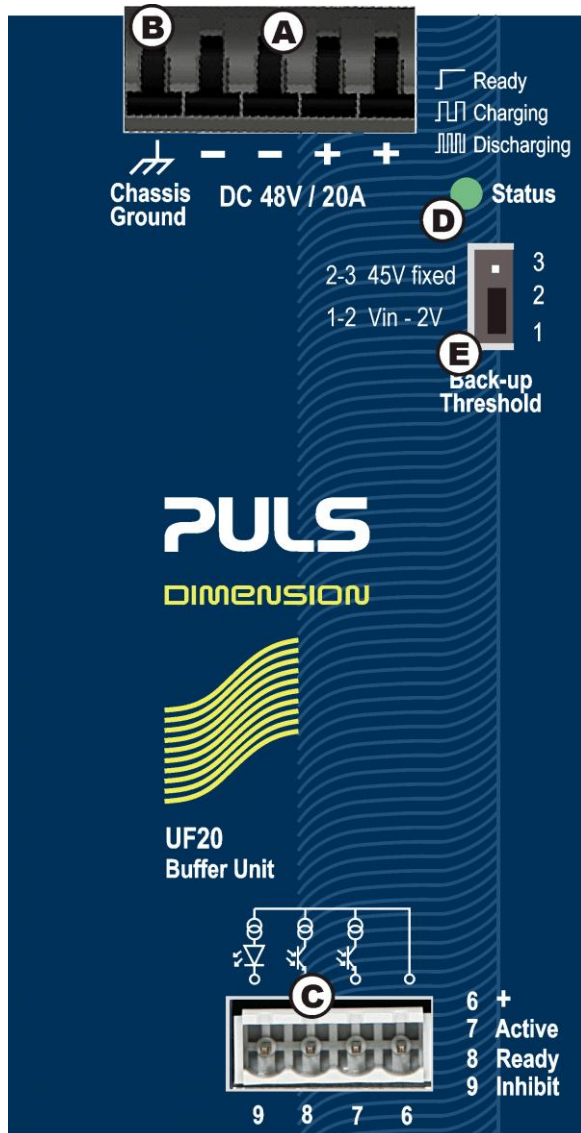

A Supply Voltage Terminals

Quick-connect spring-clamp terminals, two per polarity
 + Positive supply voltage terminal
 - Negative (return) supply voltage terminal

B Chassis Ground Terminal

Quick-connect spring-clamp terminals
 Connection of the chassis to ground (earth) is optional and only required for a view specific applications.

C Signal Connector

4-pole plug connector with screw termination comprises the following signals:

- "Active" signal, for details see chapter 9.
- "Ready" signal, for details see chapter 10
- "Inhibit" input, for details see chapter 11

D Status LED

This green LED indicates that the following information:

- OFF: Capacitors are discharged or supply voltage is below 44V.
- ON: Capacitors are fully charged
- Slow flashing (1.25Hz): Capacitors are getting charged.
- Fast flashing (10Hz): Capacitors are getting discharged.

E Back-up Threshold Jumper

Option 1: Fixed mode (Jumper in position 2-3)

The unit switches to buffer mode as soon as the voltage falls below 45V.

Option 2: Variable mode (Jumper in position 1-2)

Unit switches to buffer mode when input voltage decreases by 2V. Voltage changes slower than 1.1V/s will be ignored if the voltage is above 45V. Below 45V buffering starts immediately.

For more details see chapter 5.

17. EMC

The buffer module is suitable for applications in industrial environment as well as in residential, commercial and light industry environment.

EMC Immunity According to generic standards: EN 61000-6-1 and EN 61000-6-2
for all operating modes

Electrostatic discharge	EN 61000-4-2	Contact discharge *) Air discharge *)	8kV 15kV	Criterion A Criterion A
Electromagnetic RF field	EN 61000-4-3	80MHz-2.7GHz	10V/m	Criterion A
Fast transients (Burst)	EN 61000-4-4	Input lines Output lines Signals lines pin 6, 7, 8, 9 **)	2kV 2kV 2kV	Criterion A Criterion A Criterion A
Surge voltage on supply voltage terminals	EN 61000-4-5	+ → - + / - → chassis ground	0.5kV 1kV	Criterion A Criterion A
Surge voltage on inhibit input, active signal and ready signal	EN 61000-4-5	Not applicable since length of signal wire specified shorter than 30m.		
Conducted disturbance	EN 61000-4-6	0.15-80MHz	10V	Criterion A

*) Chassis ground connection earthed (grounded)

**) Tested with coupling clamp

Criteria:

A: Buffer module shows normal operation behavior within the defined limits.

EMC Emission According to generic standards: EN 61000-6-3 and EN 61000-6-4
for standby- and charging mode

Conducted emission, supply voltage	IEC/CISPR 16-1-2, IEC/CISPR 16-2-1	Limits for DC power ports acc. EN 61000-6-3 fulfilled
Radiated emission	EN 55011, EN 55022	Class B

This device complies with FCC Part 15 rules.

Operation is subjected to following two conditions: (1) this device may not cause harmful interference, and (2) this device must accept any interference received, including interference that may cause undesired operation.

Switching Frequency The buffer module has two converters with variable frequencies included.

6 to 740kHz	Charging converter at 48V input (is only active during charging) The frequency depends on the state of charge of the capacitors
10 to 85kHz	Buffer converter at buffering at 45V The frequency depends on the output current. The values are between 10% and 100% of the nominal buffer current

18. ENVIRONMENT

Operational temperature *)	-25°C to +70°C (-13°F to 158°F)	
Storage temperature	-40 to +70°C (-40°F to 158°F)	For storage and transportation
Humidity **)	5 to 95% r.H.	IEC 60068-2-30
Vibration sinusoidal	2-17.8Hz: ±1.6mm; 17.8-500Hz: 2g 2 hours / axis	IEC 60068-2-6
Vibration random	0.5m ² (s ³) 2 hours / axis	IEC 60068-2-64
Shock	30g 6ms, 20g 11ms 3 bumps / direction, 18 bumps in total	IEC 60068-2-27
Altitude	0 to 6000m (0 to 20 000ft)	Approvals apply only up to 2000m
Over-voltage category	III	IEC 62103, EN 62477-1
	II	IEC 62103, EN 62477-1, above 2000m altitude
Degree of pollution	2	IEC 62103, EN 62477-1, not conductive
LABS compatibility	The unit does not release any silicone or other LABS-critical substances and is suitable for use in paint shops.	

*) Operational temperature is the same as the ambient or surrounding temperature and is defined as the air temperature 2cm below the unit.

**) Do not energize while condensation is present

19. PROTECTION FEATURES

Electrical protection	Electronically protected against overload, no-load and short-circuits	
Over-voltage protection in buffer mode	Typ. 58Vdc Max. 60Vdc	In case of an internal buffer module defect, a redundant circuit limits the maximum output voltage. Buffering stops and automatically attempts to restart.
Degree of protection	IP 20	EN/IEC 60529
Penetration protection	> 3.5mm	E.g. screws, small parts
Reverse polarity protection	Yes	Max. -60V
Input overvoltage protection	No	
Internal input fuse	Not included	

20. SAFETY FEATURES

Class of protection	No classification according to IEC 61140 or IEC 60950-1 possible	Install the buffer module according to Class III rules
Isolation resistance	> 500MOhm	Supply voltage to signal port
	> 500MOhm	Supply voltage to housing
	> 500MOhm	Signal port to housing
Chassis ground terminal resistance	< 0.10hm	Between housing and chassis ground terminal

21. DIELECTRIC STRENGTH

The signal port (active and ready signal and inhibit input) is floating and separated from the supply voltage.

Type and factory tests are conducted by the manufacturer. Field tests may be conducted in the field using the appropriate test equipment which applies the voltage with a slow ramp (2s up and 2s down). Connect all poles of the power port terminals together as well as all poles of the signal port before conducting the test. When testing, set the cut-off current settings to the value in the table below. The following isolation tests were performed:

Fig. 21-1 Dielectric strength

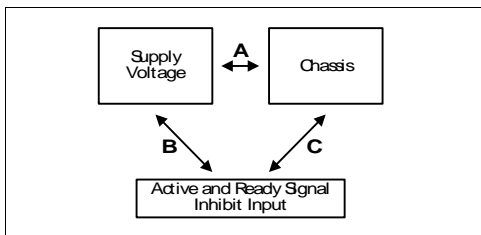

		A	B	C
Type test	60s	500Vac	500Vac	500Vac
Factory test	5s	500Vac	500Vac	500Vac
Field test	5s	500Vac	500Vac	500Vac
Cut-off current setting		> 1mA	> 1mA	> 1mA

22. APPROVALS

EU Declaration of Conformity



The CE mark indicates conformance with the EMC directive

IEC 60950-1
2nd Edition



CB Scheme,
Information Technology Equipment

UL 60950-1
2nd Edition



Recognized for use as Information Technology Equipment, U.S.A. (UL 60950-1) and Canada (C22.2 No. 60950-1);
E-File: E137006

UL 508



Listed for use as Industrial Control Equipment;
U.S.A. (UL 508) and Canada (C22.2 No. 107-1-01);
E-File: E198865

23. PHYSICAL DIMENSIONS AND WEIGHT

Width	64mm	2.52"
Height	124mm	4.88"
Depth	102mm	4.02"
	The DIN-rail height must be added to the unit depth to calculate the total required installation depth.	
Weight	740g / 1.63lb	
DIN-rail	Use 35mm DIN-rails according to EN 60715 or EN 50022 with a height of 7.5 or 15mm.	
Housing material	Body: Aluminium alloy Cover: Zinc-plated steel	
Installation clearances	See chapter 2	

Fig. 23-1 Front view

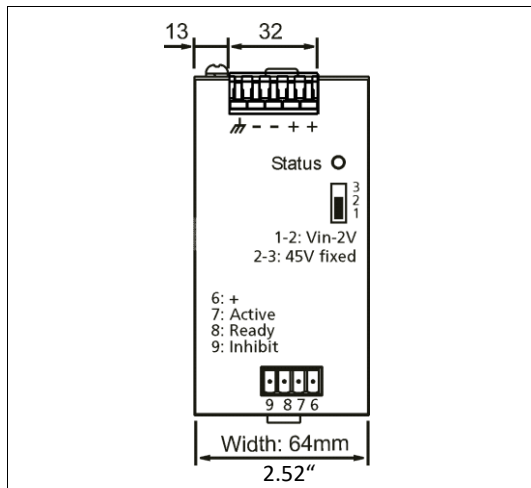
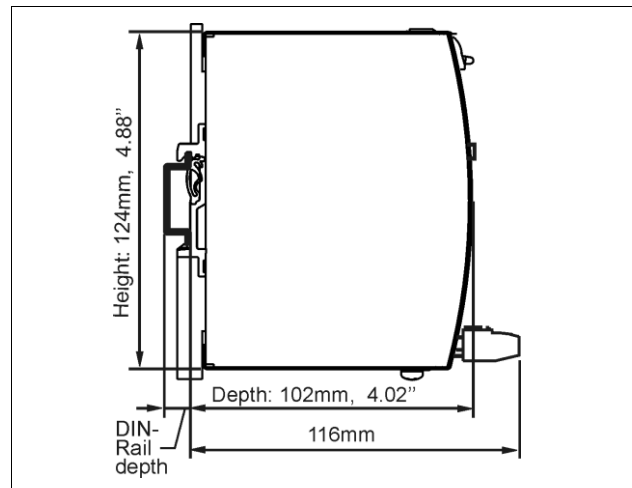

Fig. 23-2 Side view



24. ACCESSORIES

24.1. ZM1.WALL - WALL MOUNTING BRACKET



This bracket is used to mount the buffer module on a wall without utilizing a DIN-Rail.

The two aluminum brackets and the black plastic slider of the unit have to be detached, so that the steel brackets can be mounted.

Fig. 24-1 Wall mounting

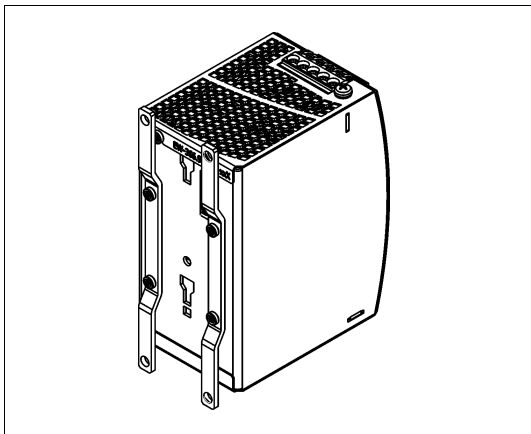
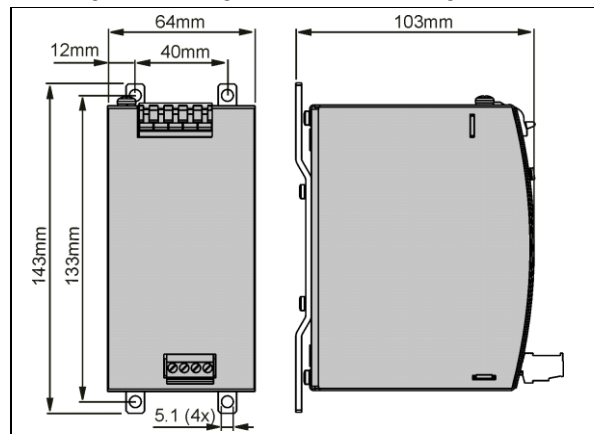

Fig. 24-2 Mounting Dimensions - Wall mounting bracket



24.2. ZM14.SIDE - SIDE MOUNTING BRACKET



This bracket is used to mount the buffer module sideways with or without utilizing a DIN-Rail.
 The two aluminum brackets and the black plastic slider of the unit have to be detached, so that the steel brackets can be mounted.
 For sideways DIN-rail mounting, the removed aluminum brackets and the black plastic slider need to be mounted on the steel bracket.

Fig. 24-3
Side mounting without DIN-rail brackets

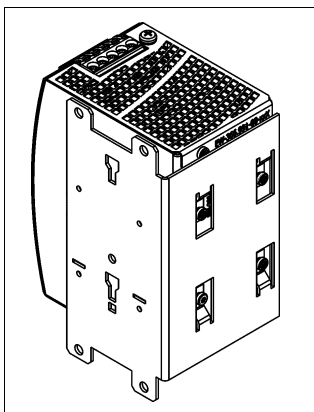

Fig. 24-4
Side mounting with DIN-rail brackets

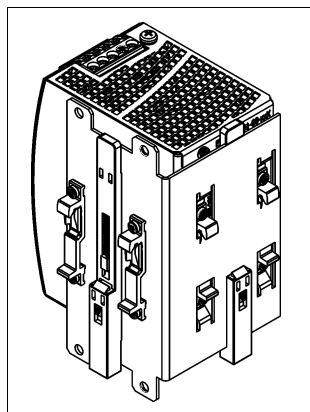
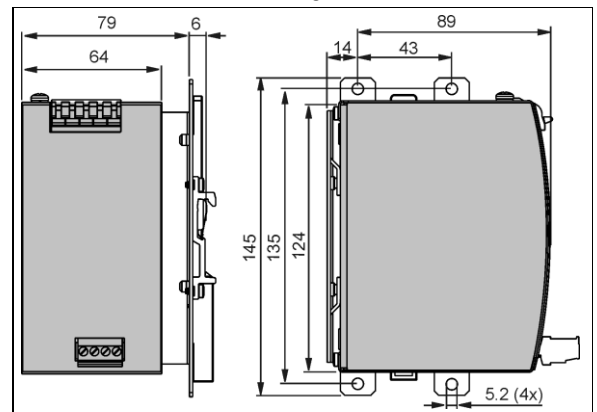

Fig. 24-5
Mounting Dimensions
Side mounting bracket



25. WIRING DIAGRAMS

Fig. 25-1 General wiring diagram

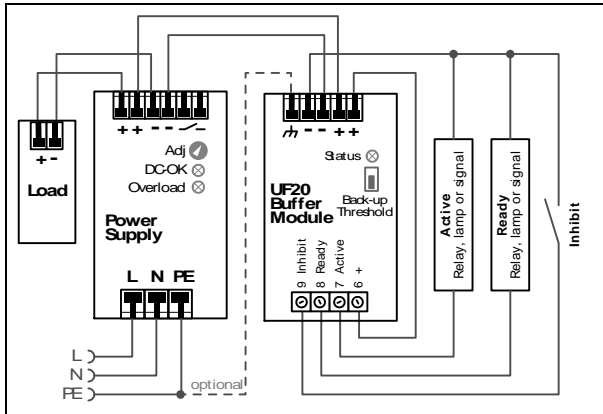

Fig. 25-2 Signals supplied from an external voltage source

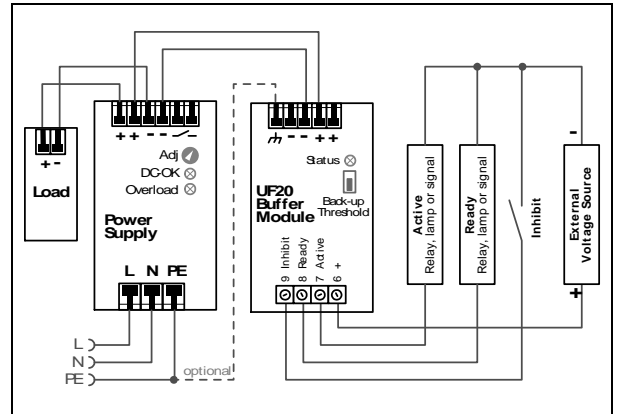

Fig. 25-3 Paralleling of buffer modules

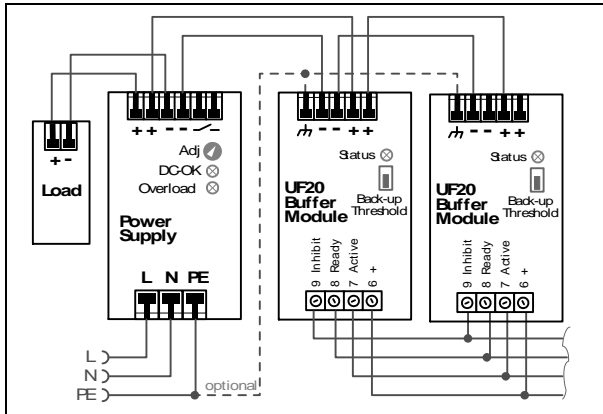

Fig. 25-4 Decoupling of buffered branches

